

MRLF100 Level Sensor

Contactless Level Sensor
Based on MR Sensors
Level Range 100 mm
Accuracy +/- 1mm
Analog/Digital Output



The MRLF100 Level sensor is driven by magnetostrictive sensors to establish a highly accurate measurement of fluid levels. A float, equipped with a small ring magnet can freely rotate around the housing tube. The bigger clearance between tube and float enables the device to work in materials with lower viscosities. The system is fully sealed to reach IP65 classification. A wide range of analog and digital interfaces are possible depending on customer demands.

FEATURES

- Full housed system
- High accuracy
- High resolution
- Analog output signal
- Digital output signal

APPLICATIONS

- Industrial ink tank levelling
- Automotive levelling
- Truck tank levelling

dimensions [mm]

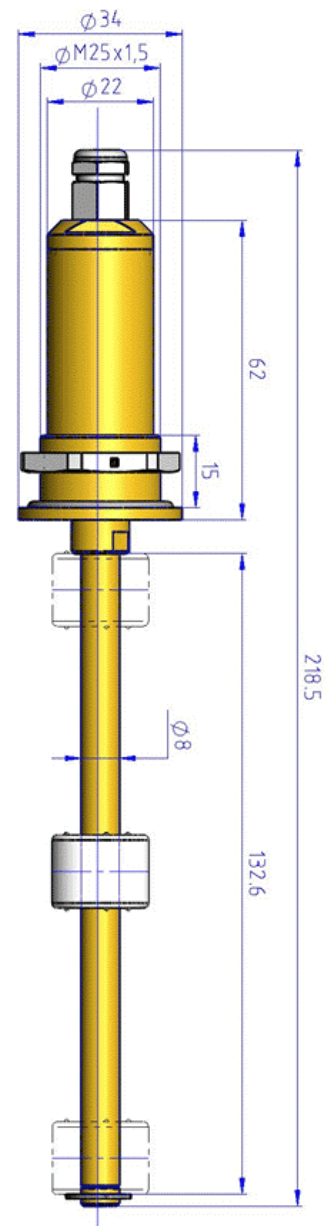

MRLF100 Level Sensor

PARAMETERS

	Conditions	Min	Type	Max	Unit
Measurement range (1)		0		100	mm
Resolution			0,5		mm
Accuracy	Ta = 0°...60°C,	-1		+1	mm
Current consumption			50		mA
Power supply		4.5	5	5.5	VDC
Operation temperature range		-0		+60	°C
Storage temperature range		-0		+85	°C
Dimensions	H x Diameter		218 x 34		mm

- (1) lengths up to 500mm on request
(2),(3) depend on measurement range

Pinning

Pin	Name	Description	Type
1	PWM	Level value coded via PWM	Output
2	Mode	Modus Switch	Input
3	RST	Internal use	Input
4	MOSI / UART_RX	GPIO	Output/Input
5	MISO / UART_TX	GPIO	Output/Input
6	SCK	GPIO	Output/Input
7	5VDC	5V Reference	Output
8	AOUT	Level value as analog value	Output
9	GND	Ground	Power Supply
10	VDC	5V Supply	Power Supply

For more details please use the product specification/ application note / instruction manual.

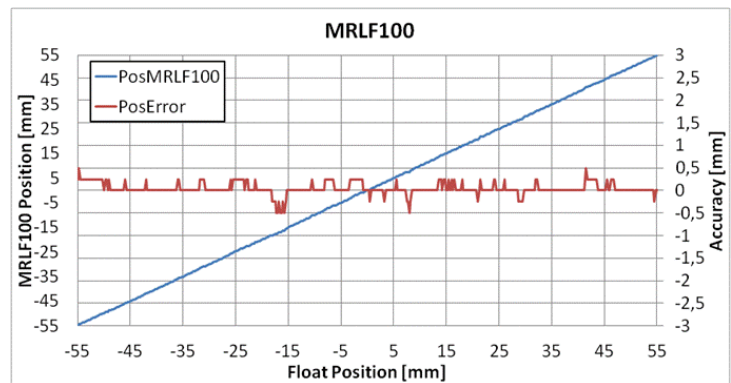

The information in this sheet has been carefully reviewed and is believed to be accurate; however, no responsibility is assumed for inaccuracies. Furthermore, this information does not convey to the purchaser of such devices any license under the patent rights to the manufacturer. Measurement Specialties, Inc. reserves the right to make changes without further notice to any product herein. Measurement Specialties, Inc. makes no warranty, representation or guarantee regarding the suitability of its product for any particular purpose, nor does Measurement Specialties, Inc. assume any liability arising out of the application or use of any product or circuit and specifically disclaims any and all liability, including without limitation consequential or incidental damages. Typical parameters can and do vary in different applications. All operating parameters must be validated for each customer application by customer's technical experts. Measurement Specialties, Inc. does not convey any license under its patent rights nor the rights of others.

ordering info

PART NUMBERING
G-MRLF-100

UNIT

SHORT DESCRIPTION